

# BGS12P2L6

## SPDT general purpose switch for high power applications

### Features

- High linearity up to 37 dBm input power
- Low insertion loss and high port to port isolation up to 6 GHz
- Low current consumption
- On-chip control logic
- Ultra low profile leadless plastic package
- RoHS and WEEE compliant package

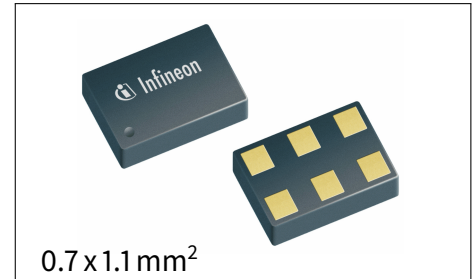

### Potential Applications

The BGS12P2L6 is a general purpose RF MOS power switch, designed to cover a broad range of high power applications from 0.05 to 6 GHz, mainly in the transmit path of GSM, WCDMA and LTE mobile phones.

### Product Validation

Qualified for industrial applications according to the relevant tests of JEDEC47/20/22.

### Block Diagram

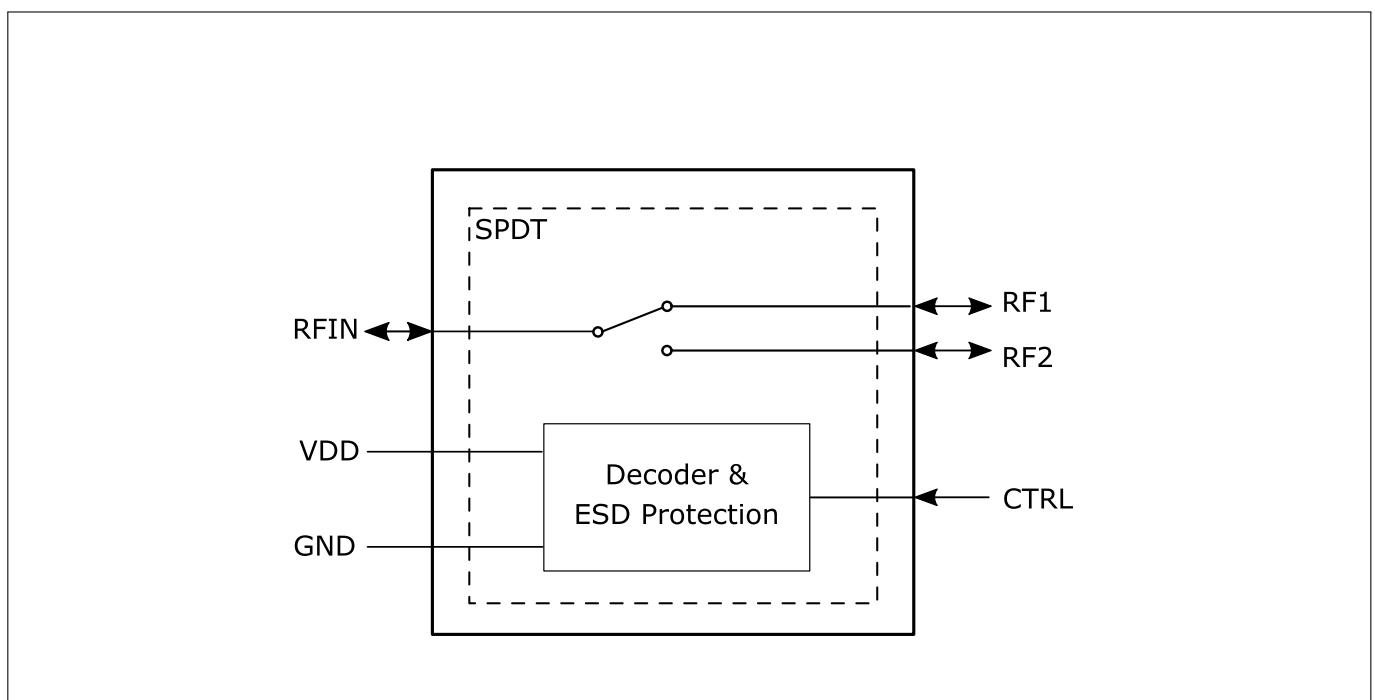

# BGS12P2L6

## SPDT general purpose switch for high power applications

---



### Table of Contents

## Table of Contents

<b>1</b>	<b>Features</b>	<b>2</b>
<b>2</b>	<b>Maximum Ratings</b>	<b>3</b>
<b>3</b>	<b>Operation Ranges</b>	<b>4</b>
<b>4</b>	<b>RF Characteristics</b>	<b>5</b>
<b>5</b>	<b>Application Information</b>	<b>8</b>
<b>6</b>	<b>Package Information</b>	<b>9</b>

# BGS12P2L6

## SPDT general purpose switch for high power applications

### Features

## 1 Features

- RF CMOS SPDT antenna switch with power handling capability of up to 37 dBm
- Suitable for multi-mode LTE and WCDMA applications
- Low insertion loss and harmonics generation
- 0.05 to 6 GHz coverage
- High port-to-port isolation
- No blocking capacitors required if no DC applied on RF lines
- On-chip control logic
- Leadless and halogen free package TSLP-6-4 with lateral size of 0.7 mm x 1.1 mm and thickness of 0.31 mm
- No power supply decoupling required
- High EMI robustness
- RoHS and WEEE compliant package

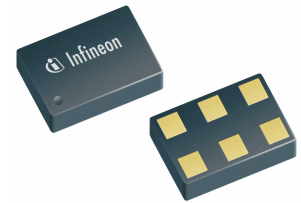

## Description

The BGS12P2L6 is a general purpose RF MOS power switch, designed to cover a broad range of high power applications from 0.05 to 6 GHz, mainly in the transmit path of GSM, WCDMA and LTE mobile phones. The chip integrates on-chip CMOS logic driven by a simple, single-pin CMOS or TTL compatible control input signal. Unlike GaAs technology, external DC blocking capacitors at the RF ports are only required if DC voltage is applied externally. The BGS12P2L6 RF switch is manufactured in Infineon's patented MOS technology, offering the performance of GaAs with the economy and integration of conventional CMOS including the inherent higher ESD robustness. The device has a very small size of only 0.7 x 1.1 mm<sup>2</sup> and a maximum height of 0.31 mm.

**Table 1: Ordering Information**

Type	Marking	Package
BGS12P2L6	U	TSLP-6-4

# BGS12P2L6

## SPDT general purpose switch for high power applications



### Maximum Ratings

## 2 Maximum Ratings

**Table 2: Maximum Ratings** at  $T_A = 25\text{ }^\circ\text{C}$ , unless otherwise specified

Parameter	Symbol	Values			Unit	Note / Test Condition
		Min.	Typ.	Max.		
Frequency Range <sup>1)</sup>	$f$	0.05	–	6	GHz	–
Supply voltage	$V_{DD}$	-0.5	–	3.6	V	–
RF input power at all RF ports	$P_{RF,max}$	–	–	38	dBm	VSWR 1:1
ESD capability, CDM <sup>2)</sup>	$V_{ESD,CDM}$	-1	–	+1	kV	–
ESD capability, HBM <sup>3)</sup>	$V_{ESD,HBM}$	-1	–	+1	kV	–
ESD capability RF ports <sup>4)</sup>	$V_{ESD,RF}$	-8	–	+8	kV	Each single RF-in/out port versus GND, with 27 nH shunt inductor
		-6	–	+6	kV	Each single RF-in/out port versus GND, with 56 nH shunt inductor
Thermal resistance junction - soldering point	$R_{thJS}$	–	68	80	K/W	–
Maximum DC-voltage on RF ports and RF-Ground	$V_{RFDC}$	0	–	0	V	No DC voltages allowed on RF-Ports
Storage temperature range	$T_{STG}$	-55	–	150	$^\circ\text{C}$	–
Junction temperature	$T_j$	–	–	125	$^\circ\text{C}$	–

<sup>1)</sup> There is also a DC connection between switched paths. The DC voltage at RF ports  $V_{RFDC}$  has to be 0 V.

<sup>2)</sup> Field-Induced Charged-Device Model ANSI/ESDA/JEDEC JS-002. Simulates charging/discharging events that occur in production equipment and processes. Potential for CDM ESD events occurs whenever there is metal-to-metal contact in manufacturing.

<sup>3)</sup> Human Body Model ANSI/ESDA/JEDEC JS-001 ( $R = 1.5\text{ k}\Omega$ ,  $C = 100\text{ pF}$ ).

<sup>4)</sup> IEC 61000-4-2 ( $R = 330\ \Omega$ ,  $C = 150\text{ pF}$ ), contact discharge.

**Warning: Stresses above the max. values listed here may cause permanent damage to the device. Maximum ratings are absolute ratings; exceeding only one of these values may cause irreversible damage to the integrated circuit. Exposure to conditions at or below absolute maximum rating but above the specified maximum operation conditions may affect device reliability and life time. Functionality of the device might not be given under these conditions.**

# BGS12P2L6

## SPDT general purpose switch for high power applications



### Operation Ranges

## 3 Operation Ranges

**Table 3: Operation Ranges**, at  $T_A = -40\text{ }^{\circ}\text{C} \dots 85\text{ }^{\circ}\text{C}$ ,  $V_{DD} = 1.65\text{ V} \dots 3.4\text{ V}$

Parameter	Symbol	Values			Unit	Note / Test Condition
		Min.	Typ.	Max.		
Supply voltage	$V_{DD}$	1.65	1.8	3.4	V	–
Supply current	$I_{DD}$	–	65	110	$\mu\text{A}$	Operating State
Control voltage Low	$V_{Ctrl,L}$	-0.3	–	0.43	V	–
Control voltage High	$V_{Ctrl,H}$	1.35	–	$V_{DD}$	V	–
Control current	$I_{Ctrl}$	–	2	10	nA	–
Ambient temperature	$T_A$	-40	25	85	$^{\circ}\text{C}$	–

**Table 4: RF Input Power**

Parameter	Symbol	Values			Unit	Note / Test Condition
		Min.	Typ.	Max.		
RF input power at all RF ports	$P_{RF}$	–	–	37	dBm	VSWR 1:1 / $50\ \Omega$

RF Characteristics

**4 RF Characteristics**

**Table 5: RF Characteristics<sup>1)</sup>** at  $T_A = -40\text{ }^\circ\text{C} \dots 85\text{ }^\circ\text{C}$ ,  $P_{RF} = 0\text{ dBm}$ ,  $V_{DD} = 1.65\text{ V} \dots 3.4\text{ V}$ , unless otherwise specified

Parameter	Symbol	Values			Unit	Note / Test Condition
		Min.	Typ.	Max.		
<b>Insertion Loss<sup>1)</sup></b> at $T_A = 25\text{ }^\circ\text{C}$ , $V_{DD} = 1.8\text{ V}$						
All TRx Ports	IL	-	0.20	0.23	dB	617–960 MHz
		-	0.25	0.34	dB	960–2170 MHz
		-	0.31	0.39	dB	2170–2700 MHz
		-	0.39	0.47	dB	3300–3800 MHz
		-	0.42	0.48	dB	3800–4200 MHz
		-	0.47	0.55	dB	4400–5000 MHz
		-	0.51	0.64	dB	5150–5925 MHz
<b>Insertion Loss<sup>1)</sup></b>						
All TRx Ports	IL	-	0.20	0.28	dB	617–960 MHz
		-	0.25	0.38	dB	960–2170 MHz
		-	0.31	0.40	dB	2170–2700 MHz
		-	0.39	0.50	dB	3300–3800 MHz
		-	0.42	0.52	dB	3800–4200 MHz
		-	0.47	0.62	dB	4400–5000 MHz
		-	0.51	0.74	dB	5150–5925 MHz
<b>Return Loss<sup>1)</sup></b>						
All TRx Ports	RL	23	27	-	dB	617–960 MHz
		17	22	-	dB	960–2170 MHz
		16	19	-	dB	2170–2700 MHz
		15	17	-	dB	3300–3800 MHz
		15	16	-	dB	3800–4200 MHz
		14	15	-	dB	4400–5000 MHz
		12	14	-	dB	5150–5925 MHz
<b>Isolation<sup>1)</sup></b>						
RFin to RF1/RF2 Port	$ISO_{RFin-RFx}$	42	45	-	dB	617–960 MHz
		34	39	-	dB	960–2170 MHz
		32	35	-	dB	2170–2700 MHz
		29	32	-	dB	3300–3800 MHz
		28	31	-	dB	3800–4200 MHz
		26	29	-	dB	4400–5000 MHz
		24	27	-	dB	5150–5925 MHz
RF1 to RF2 Port / RF2 to RF1 Port	$ISO_{RFx-RFx}$	48	54	-	dB	617–960 MHz
		40	47	-	dB	960–2170 MHz
		38	43	-	dB	2170–2700 MHz
		35	39	-	dB	3300–3800 MHz
		34	37	-	dB	3800–4200 MHz
		31	35	-	dB	4400–5000 MHz
		30	34	-	dB	5150–5925 MHz

<sup>1)</sup> Measured on Application board, without any matching components.

# BGS12P2L6

## SPDT general purpose switch for high power applications



### RF Characteristics

**Table 6: RF Characteristics<sup>1)</sup>** at  $T_A = -40\text{ }^{\circ}\text{C} \dots 85\text{ }^{\circ}\text{C}$ ,  $P_{RF} = 0\text{ dBm}$ , Supply Voltage  $V_{DD} = 1.65\text{ V} \dots 3.4\text{ V}$ , unless otherwise specified

Parameter	Symbol	Values			Unit	Note / Test Condition
		Min.	Typ.	Max.		
<b>Harmonic Generation on all RF Ports<sup>2)</sup></b> at $50\text{ }\Omega$ , VSWR 1:1, unless otherwise specified						
2 <sup>nd</sup> Harmonic	$P_{H2}$	-	-71	-62	dBm	617–960 MHz, 35 dBm
		-	-75	-68	dBm	960–2170 MHz, 33 dBm
		-	-83	-78	dBm	2170–2700 MHz, 26 dBm
		-	-78	-73	dBm	3300–3800 MHz, 26 dBm
		-	-78	-72	dBm	3800–4200 MHz, 26 dBm
		-	-78	-73	dBm	4400–5000 MHz, 26 dBm
		-	-76	-65	dBm	5150–5925 MHz, 26 dBm
3 <sup>rd</sup> Harmonic	$P_{H3}$	-	-57	-52	dBm	617–960 MHz, 35 dBm
		-	-62	-57	dBm	960–2170 MHz, 33 dBm
		-	-81	-75	dBm	2170–2700 MHz, 26 dBm
		-	-80	-75	dBm	3300–3800 MHz, 26 dBm
		-	-80	-75	dBm	3800–4200 MHz, 26 dBm
		-	-79	-73	dBm	4400–5000 MHz, 26 dBm
		-	-79	-73	dBm	5150–5925 MHz, 26 dBm
<b>Intercept Point<sup>1)</sup></b>						
IIP2	$IIP2$	124	130	-	dBm	Testcases see Table 7
IIP3	$IIP3$	71	74	-	dBm	Testcases see Table 8

<sup>1)</sup> Measured on Application board, without any matching components.

<sup>2)</sup> Measured on Application board, with 1 nF blocking capacity between  $V_{DD}$  to GND and  $V_{CTRL}$  to GND.

**Table 7: IMD2 Testcases**

Band	Symbol	In-Band Frequency (MHz)	Blocker Frequency 1 (MHz)	Blocker Power 1 (dBm)	Blocker Frequency 2 (MHz)	Blocker Power 2 (dBm)
Band 1	$B1_{IMD2,OOB}$	2140	1950	24	4090	-15
Band 5	$B5_{IMD2,ULCA}$	881.5	836.5	20	1718	20
Band 7	$B7_{IMD2,OOB}$	2652	2535	20	5187	20

**Table 8: IMD3 Testcases**

Band	Symbol	In-Band Frequency (MHz)	Blocker Frequency 1 (MHz)	Blocker Power 1 (dBm)	Blocker Frequency 2 (MHz)	Blocker Power 2 (dBm)
Band 1	$B1_{IMD3,ULCA}$	2140	1950	20	1760	20
Band 7	$B7_{IMD3,ULCA}$	2655	2535	20	2415	20
Band 8	$B8_{IMD3,ULCA}$	942	897	20	852	20

# BGS12P2L6

## SPDT general purpose switch for high power applications



### RF Characteristics

**Table 9: Switching Time** at  $T_A = 25\text{ }^\circ\text{C}$ ,  $P_{RF} = 0\text{ dBm}$ , Supply Voltage  $V_{DD} = 1.65\text{ V} \dots 3.4\text{ V}$ , unless otherwise specified

Parameter	Symbol	Values			Unit	Note / Test Condition
		Min.	Typ.	Max.		
<b>Switching Time<sup>1)</sup></b>						
Switching Time	$t_{ST}$	-	1.5	2.5	$\mu\text{s}$	Time between RF states in active mode $V_{Ctrl,H}$ Min. or $V_{Ctrl,L}$ Max. level to 90% RF-signal
RF Rise Time	$t_{RT}$	-	0.7	1.5	$\mu\text{s}$	Time between 10% to 90% RF Signal
Power Up Settling Time	$t_{PUP}$	-	5	7.5	$\mu\text{s}$	Time from $V_{DD}$ Min. power level to 90% RF-signal

<sup>1)</sup>On application board without any matching components.

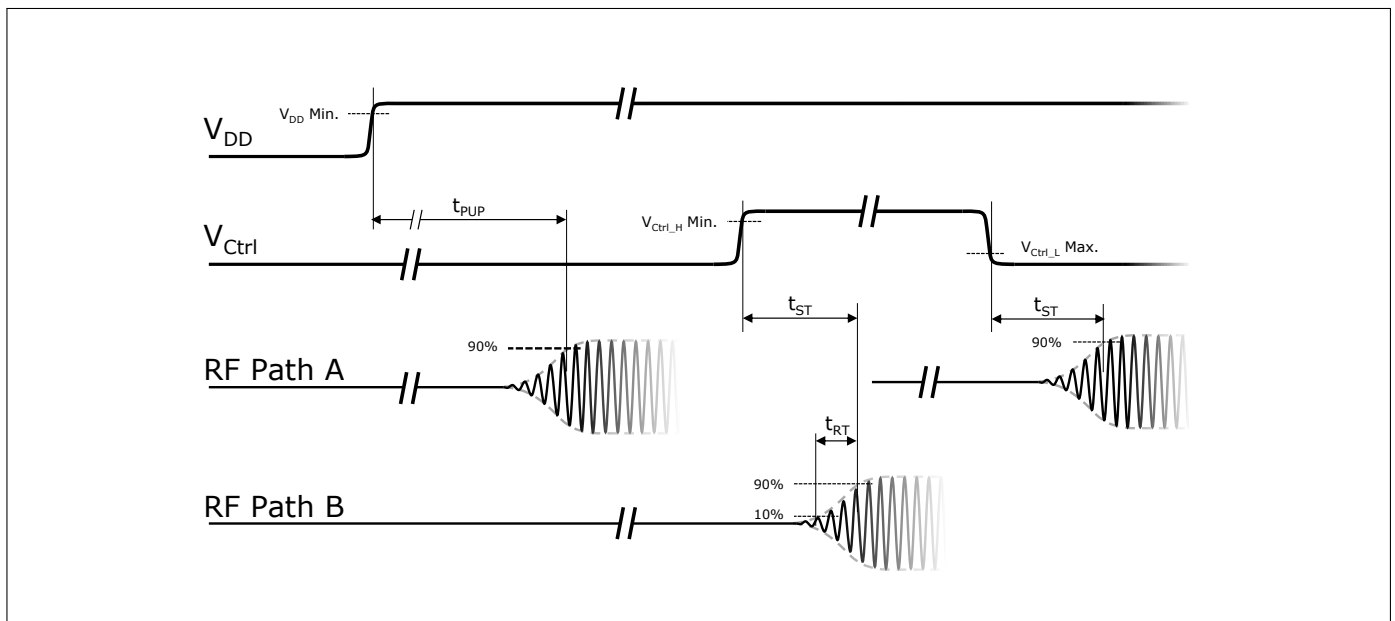

**Figure 1: CTRL to RF Time**

# BGS12P2L6

## SPDT general purpose switch for high power applications

### Application Information

## 5 Application Information

### Pin Configuration and Function

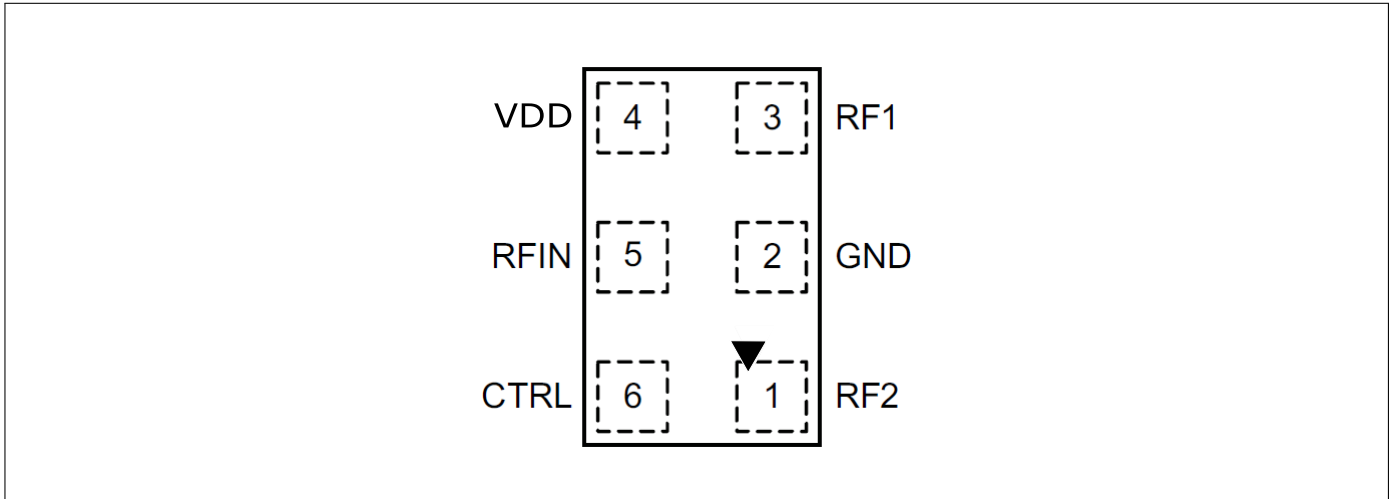

**Figure 2:** BGS12P2L6 Pin Configuration (top view)

**Table 10: Pin Definition and Function**

Pin No.	Name	Function
1	RF2	RF port 2
2	GND	Ground
3	RF1	RF port 1
4	VDD	Supply voltage
5	RFin	RF port In
6	CTRL	Control pin

**Table 11: Truth Table Switch Control**

Switched Paths	CTRL
RFIN - RF1	0
RFIN - RF2	1



# BGS12P2L6

## SPDT general purpose switch for high power applications

### Package Information

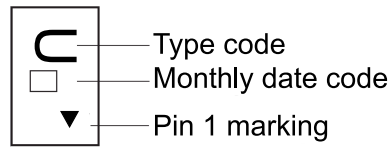

**Figure 5:** Marking Specification (Top View): Monthly Date code specified in Table 13

**Table 13: Monthly Date Code Marking**

Month	2015	2016	2017	2018	2019	2020	2021	2022	2023	2024	2025	2026
1	a	p	A	P	a	p	A	P	a	p	A	P
2	b	q	B	Q	b	q	B	Q	b	q	B	Q
3	c	r	C	R	c	r	C	R	c	r	C	R
4	d	s	D	S	d	s	D	S	d	s	D	S
5	e	t	E	T	e	t	E	T	e	t	E	T
6	f	u	F	U	f	u	F	U	f	u	F	U
7	g	v	G	V	g	v	G	V	g	v	G	V
8	h	x	H	X	h	x	H	X	h	x	H	X
9	j	y	J	Y	j	y	J	Y	j	y	J	Y
10	k	z	K	Z	k	z	K	Z	k	z	K	Z
11	l	2	L	4	l	2	L	4	l	2	L	4
12	n	3	N	5	n	3	N	5	n	3	N	5

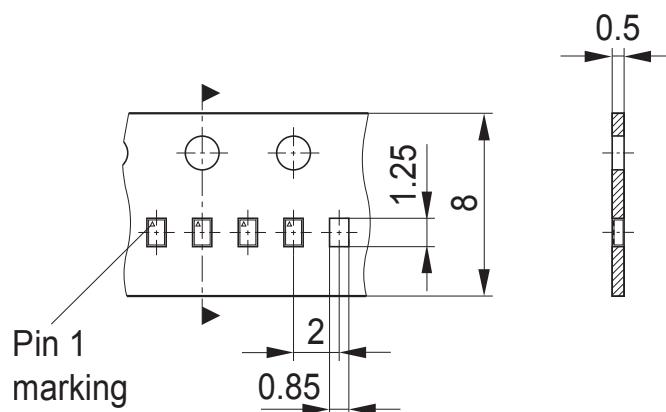

**Figure 6:** TSLP-6-4 Carrier Tape Drawing (Top and Side Views)

**BGS12P2L6**  
**SPDT general purpose switch for high power applications**

---



---

**Revision History**

---

**Target, Revision v1.1, 2019-06-11**

---

<b>Page or Item</b>	<b>Subjects (major changes since previous revision)</b>
---------------------	---

---

**Revision 2.0, 2019-07-04**

5-7	RF Characteristics Table 6
-----	----------------------------

---

#### Other Trademarks

All referenced product or service names and trademarks are the property of their respective owners.

**Edition 2019-07-04**  
**Published by**  
**Infineon Technologies AG**  
**81726 Munich, Germany**

**© 2019 Infineon Technologies AG.**  
**All Rights Reserved.**

**Do you have a question about any aspect of this document?**  
**Email: [erratum@infineon.com](mailto:erratum@infineon.com)**

#### IMPORTANT NOTICE

The information given in this document shall in no event be regarded as a guarantee of conditions or characteristics ("Beschaffenheitsgarantie"). With respect to any examples, hints or any typical values stated herein and/or any information regarding the application of the product, Infineon Technologies hereby disclaims any and all warranties and liabilities of any kind, including without limitation warranties of non-infringement of intellectual property rights of any third party. In addition, any information given in this document is subject to customer's compliance with its obligations stated in this document and any applicable legal requirements, norms and standards concerning customer's products and any use of the product of Infineon Technologies in customer's applications. The data contained in this document is exclusively intended for technically trained staff. It is the responsibility of customer's technical departments to evaluate the suitability of the product for the intended application and the completeness of the product information given in this document with respect to such application.

For further information on technology, delivery terms and conditions and prices, please contact the nearest Infineon Technologies Office ([www.infineon.com](http://www.infineon.com)).

#### WARNINGS

Due to technical requirements products may contain dangerous substances. For information on the types in question please contact your nearest Infineon Technologies office.

Except as otherwise explicitly approved by Infineon Technologies in a written document signed by authorized representatives of Infineon Technologies, Infineon Technologies products may not be used in any applications where a failure of the product or any consequences of the use thereof can reasonably be expected to result in personal injury.

# Mouser Electronics

Authorized Distributor

Click to View Pricing, Inventory, Delivery & Lifecycle Information:

[Infineon:](#)

[BGS12P2L6E6327XTSA1](#)